

VOLET À AUVENT EXTÉRIEUR

La gamme de profilés d'aluminium de la Série 68 STH permet la production de différents cadres de volet à auvent ouvrant vers l'extérieur. Ce système de fenêtres, fabriqué par Alumico Architectural inc., est en conformité avec les caractéristiques suivantes:

La fabrication du système de fenêtres est faite selon le principe de l'écran pluvial. Les profilés d'aluminium extérieurs et intérieurs du cadre et du volet sont reliés par le système SUPERTHERMIK 68™ composé de deux barrettes de polyamide de nylon 6/6 renforcé de fibre de verre, extrudées mécaniquement, munies sur toute leur longueur de deux cordons de colle et assemblées par moletage et sertissage de façon à obtenir un ensemble solide résistant à une pression minimale en cisaillement de 400 Kg sur une longueur de 100mm. Le moletage et sertissage des profilés est réalisé en continu assurant la solidité et l'étanchéité entre les profilés. Les coins des volets sont coupés à onglets, réunis et renforcés par des équerres d'assemblage pressées mécaniquement pour obtenir des joints robustes. L'assemblage hors tout du cadre a une **profondeur de 60mm (2 3/8")**, de **68mm (2 11/16")**, de **114mm (4 1/2")** ou de **152mm (6")**. Les volets Robustes ont une **profondeur de 68mm (2 11/16")**. Les parclozes de type carrées ou arrondies s'installent à pression et sont munies d'une garniture pare-air/eau profilée à double densité. Toutes les composantes d'aluminium sont faites de l'alliage 6063 de la trempe T5.

OUTSWING AWNING SASH

The complete range of 68 STH Series aluminum profiles allows the production of outswing awning sash frames. This window system, manufactured by Alumico Architectural Inc., complies with the following specifications: manufacturing of the window system according to the rainscreen principle. External and internal aluminum frame and sash extrusions are connected using the SUPERTHERMIK 68™ system, which consists of two mechanically extruded glass-reinforced polyamide nylon 6/6 struts, each equipped along its entire length with two adhesive strips, knurled and crimped to achieve a solid assembly resistant to a minimum shearing pressure of 400 kg over a length of 100 mm. The knurling and crimping of profiles are continuous, ensuring the integrity and seal between them. The corners of the sash are miter-cut, joined, and reinforced by mechanically pressed assembly brackets to obtain robust joints. The frame assembly can accommodate depths of **60 mm (2 3/8")**, **68 mm (2 11/16")**, **114 mm (4 1/2")**, and **152 mm (6")**. Heavy-Duty sashes have a **depth of 68 mm (2 11/16")**. The glass stops are of the square or rounded type, equipped with a pressure and air/water barrier gasket of dual density profile. All aluminum components are made of 6063 alloy with T5 temper.

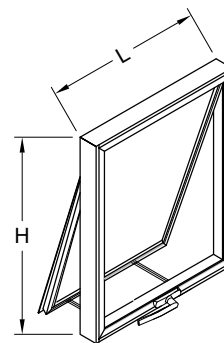

Dimensions limites de volet Limit Sash Dimensions

Robuste
AL6362
Heavy duty

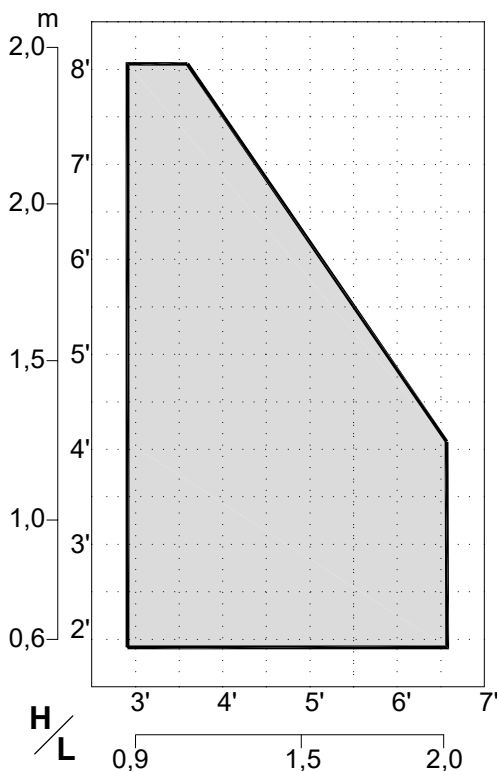
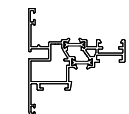

Poids maximum du volet
Maximum Sash Weight **95 kg**

Quincaillerie Hardware

Numéro de pièce Part Number

STANDARD

Crémone longue Long cremone	F0534D
Mécanisme d'ouverture Opening mechanism	F01788
Ensemble fermeture multipoint Multipoint closure kit	F01740A & F01745
Fermeture sur angle Corner closure	F01789C
Charnière régulière Regular hinge	F09826B
Moustiquaire encastrée ou anti-vandalisme Recessed or vandal-proof screen	MS04 & MS05

OPTIONS

Poignée à griffe Claw handle	PT2442
Commande rotative Roto operator	RT15376
Poignée pour commande rotative Handle for roto-operator	PT12616
Poignée pliable pour commande rotative Foldable handle for roto-operator	PT15313
Crémone longue pour perche à crochet Long cremone for hook pole	F0534DP
Crémone courte, à clé, pour perche à crochet Short cremone, with lock, for hook pole	F0530B & F0531B & F0530BP
Perche à crochet Hook pole	PRH06 & PRH12
Moustiquaire anti-vandalisme avec mèche en acier inoxydable Vandal-proof screen with STS mesh	MS06

Détails techniques disponibles
www.alumico.com
Technical details available

ÉLÉVATION ET DÉTAILS STANDARDS STANDARD ELEVATION AND DETAILS

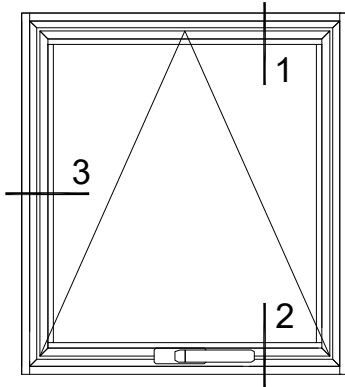

1

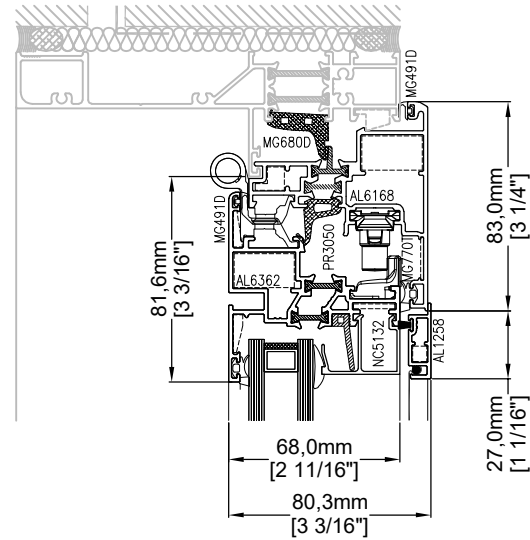

2

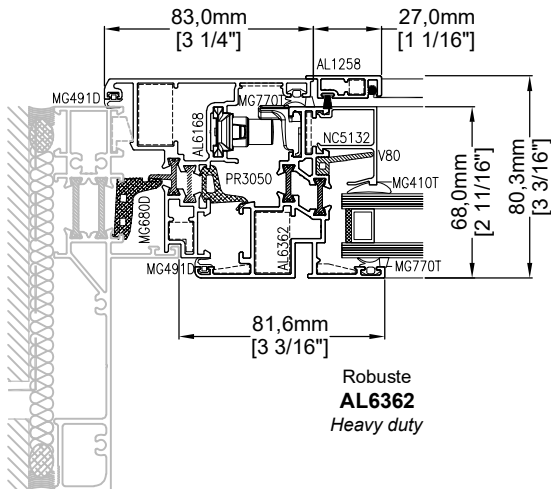
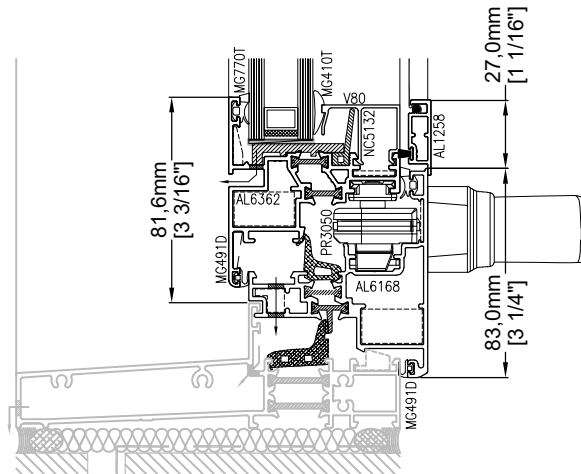

3

Volet / Sash	Divisions	Parcloses et épaisseurs de vitrage / Glass stops and thicknesses			
Robuste Heavy duty	 AL8651	 NC5132 NC5132R AL1265*	 NC5130 NC5130R AL1264*	 NC5128 AL8215*	 NC5127M*
		25,0mm [1"]	33,0mm [1 5/16"]	40,0mm [1 9/16"]	48,0mm [1 7/8"]

* Parcloses / Glass stops performance: AW

Mur rideau / Curtain wall

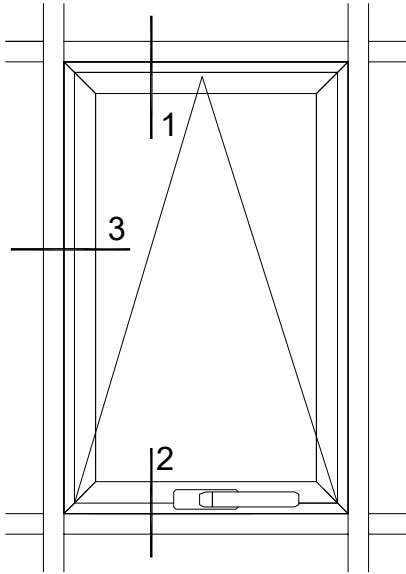

1

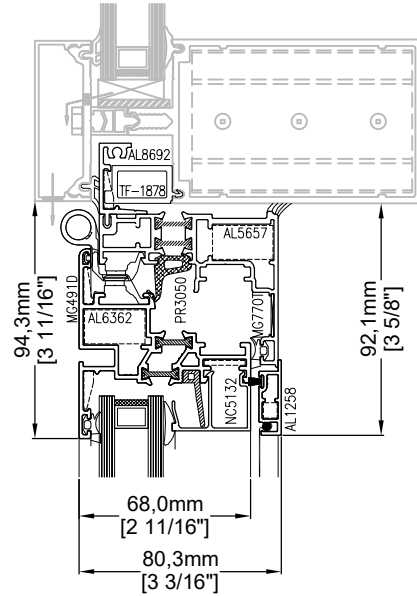

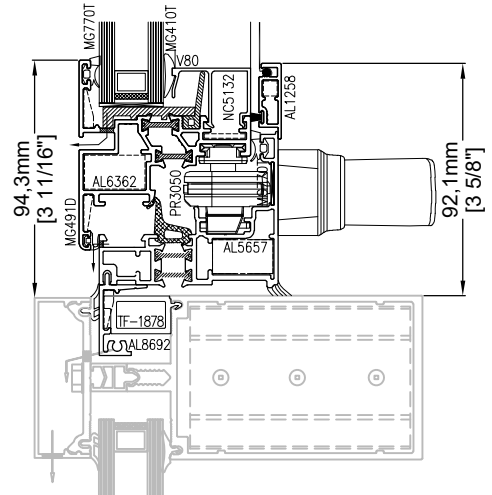

2



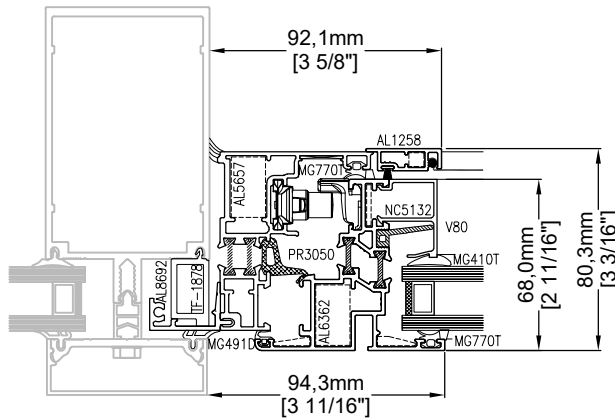

3

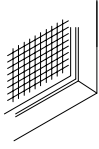

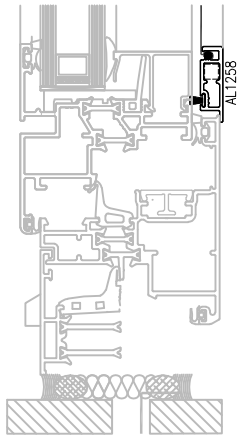
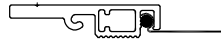
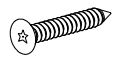
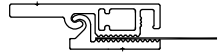
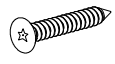
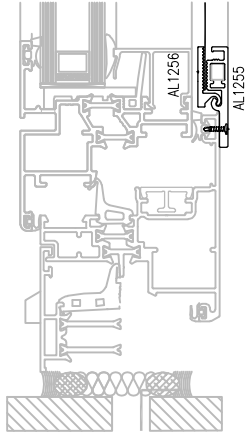

Robuste
AL6362
Heavy duty

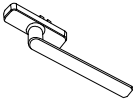
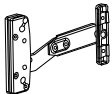
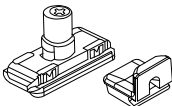
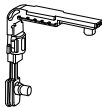
Moustiquaire / Screen			
Image	Description	Numéro de pièce <i>Part number</i>	Detail
	MS04 Mèche: Aluminium noir 16 x 18 x 0,2mm <i>Mesh: Black aluminum 16 x 18 x 0,009"</i>	AL1258  MC1844N3 	
	Fixation: Encastré avec ressort <i>Fastening: Recessed with spring</i>		
	MS05 Mèche: Aluminium noir 16 x 18 x 0,2mm <i>Mesh: Black aluminum 16 x 18 x 0,009"</i>	AL1255  Torx® security 	
Fixation: Anti-vandalisme <i>Fastening: Vandal-proof</i>			
MS06 Mèche: Acier inoxydable noir/gris 12 x 12 x 0,5mm <i>Mesh: Black/Grey stainless steel 12 x 12 x 0,023"</i>	AL1255 + AL1256  Torx® security 		
Fixation: Anti-vandalisme <i>Fastening: Vandal-proof</i>			

Quincaillerie Standard Hardware

Image	Description	Numéro de pièce <i>Part number</i>	Note
	Crémone Longue <i>Long cremone</i>	F0534D	Position std : Base Option : Jambage <i>Std location: Bottom</i> <i>Option: Jamb</i>
	Mécanisme d'ouverture <i>Opening mechanism</i>	F01788	Ouverture possible 100mm (4") 125mm (5") <i>Allowable opening</i>
	Ensemble fermeture multipoint <i>Multipoint closure kit</i>	F01740A F01745	
	Fermeture sur angle <i>Corner closure</i>	F01789C	
	Charnière régulière <i>Regular hinge</i>	F09826B	

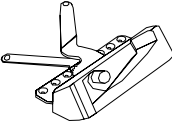
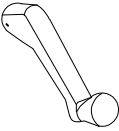
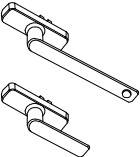
Options: Quincaillerie / Hardware

	Poignée à griffe <i>Claw handle</i>	PT2442	Finis Disponibles: <i>Available finishes:</i> - Gris / Grey - Brun / Brown - Noir / Black - Blanc / White
	Commande rotative <i>Roto-operator</i>	TR52.11	
	Poignée pour commande rotative <i>Operator Handle for roto-operator</i> Poignée pliable pour commande rotative <i>Foldable handle for roto-operator</i>	PT12616 PT15313	
	Crémone longue pour perche à crochet <i>Long cremone for hook pole</i> Crémone courte, à clé ou pour perche à crochet <i>Short cremone, with lock or for hook pole</i>	F0534DP F0530B / F0531B / F0530BP	Position std : Base Option : Jambage <i>Std location: Bottom</i> <i>Option: Jamb</i>
	Perche à crochet <i>Hook pole</i>	PRH06 (1,8m/6') PRH12 (3,6m/12')	