

PORTE TERRASSE INTÉRIEUR ET EXTÉRIEUR

La gamme de profilés d'aluminium de la Série 68 STH permet la production de différents cadres de porte terrasse ouvrant vers l'intérieur ou l'extérieur. Ce système de portes, fabriqué par Alumico Architectural inc., est en conformité avec les caractéristiques suivantes:

La fabrication du système de portes est faite selon le principe de l'écran pluvial. Les profilés d'aluminium extérieurs et intérieurs du cadre et du volet sont reliés par le système SUPERTHERMIK 68™ composé de deux barrettes de polyamide de nylon 6/6 renforcé de fibre de verre, extrudées mécaniquement, munies sur toute leur longueur de deux cordons de colle et assemblées par moletage et sertissage de façon à obtenir un ensemble solide résistant à une pression minimale en cisaillement de 400 Kg sur une longueur de 100mm. Le moletage et sertissage des profilés est réalisé en continu assurant la solidarité et l'étanchéité entre les profilés. Les coins des volets sont coupés à onglets, réunis et renforcés par des équerres d'assemblage pressées mécaniquement pour obtenir des joints robustes. L'assemblage hors tout du cadre a une **profondeur de 60mm (2 3/8")**, de **68mm (2 11/16")**, de **114mm (4 1/2")** ou de **152mm (6")**. Les volets de portes ont une **profondeur de 68mm (2 11/16")**. Les parclozes de type carrées ou arrondies s'installent à pression et sont munies d'une garniture pare-air/eau profilée à double densité. Toutes les composantes d'aluminium sont faites de l'alliage 6063 de la trempe T5.

INSWING AND OUTSWING TERRACE DOOR

The complete range of 68 STH Series aluminum profiles allows the production of inswing or outswing terrace door frames. This door system, manufactured by Alumico Architectural Inc., complies with the following specifications: manufacturing of the door system according to the rainscreen principle. External and internal aluminum frame and sash extrusions are connected using the SUPERTHERMIK 68™ system, which consists of two mechanically extruded glass-reinforced polyamide nylon 6/6 struts, each equipped along its entire length with two adhesive strips, knurled and crimped to achieve a solid assembly resistant to a minimum shearing pressure of 400 kg over a length of 100 mm. The knurling and crimping of profiles are continuous, ensuring the integrity and seal between them. The corners of the sash are miter-cut, joined, and reinforced by mechanically pressed assembly brackets to obtain robust joints. The frame assembly can accommodate depths of **60 mm (2 3/8")**, **68 mm (2 11/16")**, **114 mm (4 1/2")**, and **152 mm (6")**. Door sashes have a **depth of 68 mm (2 11/16")**. The glass stops are of the square or rounded type, equipped with a pressure and air/water barrier gasket of dual density profile. All aluminum components are made of 6063 alloy with T5 temper.

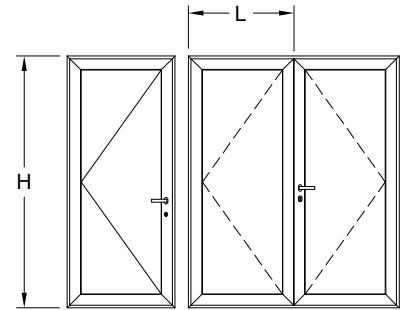

Dimensions limites de volet Limit Sash Dimensions

OUVRANT INT INSWING

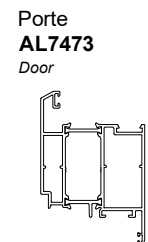

OUVRANT EXT OUTSWING

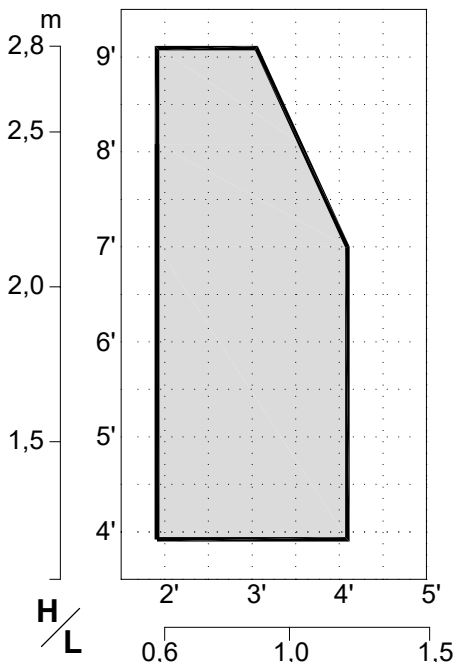
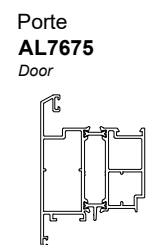

Poids maximum du volet
Maximum Sash Weight 100 kg

Quincaillerie Hardware	Numéro de pièce Part Number
STANDARD	
Poignée Prima intérieure et extérieure <i>Prima handle - interior and exterior</i>	G02792
Serrure multipoint <i>Multipoint lock</i>	G04646
Cylindre à clé extérieur et manuel intérieur <i>Key cylinder interior and thumbturn exterior</i>	G046436 & G04637
Charnière ajustable robuste <i>Robust adjustable hinge</i>	F05672
Limiteur d'ouverture <i>Limit arm</i>	G012953
Ensemble de fermeture multipoint <i>Multipoint closure kit</i>	G1343 & G4030
Fermeture multipoint avec retour d'angle <i>Multipoint closure system with back angle</i>	G04019
OPTIONS	
Cylindre à clé intérieur et extérieur <i>Key cylinder - interior and exterior</i>	G07687
Demi cylindre <i>Half cylinder</i>	G04647 & G04635
Ensemble de verrous affleurants <i>Set of flushbolt</i>	G02008 & G01339
Moustiquaire rétractable <i>Retractable screen</i>	MS10

Détails techniques disponibles
www.alumico.com
Technical details available

Ouvrant intérieur / Inswing

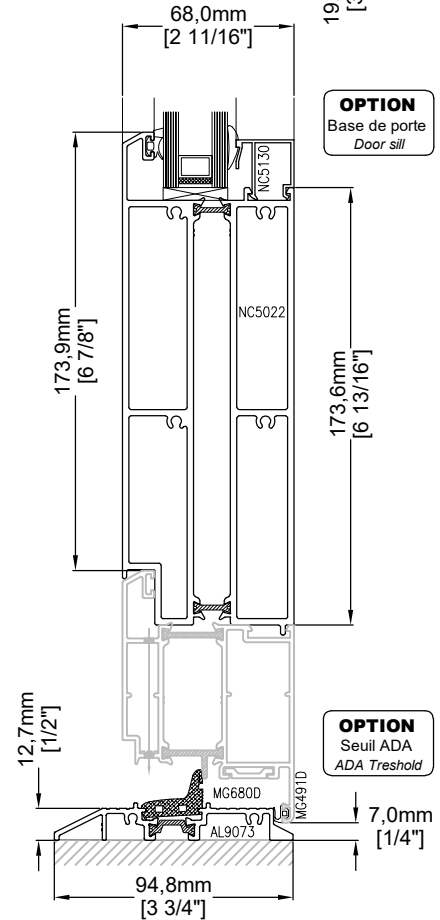
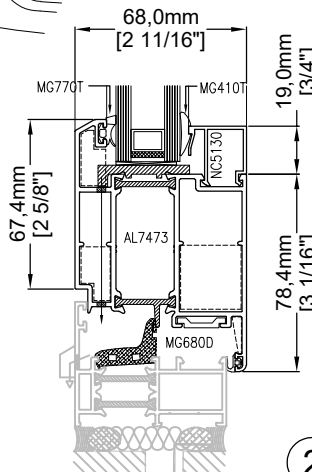
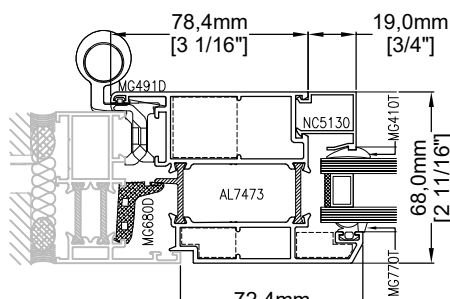
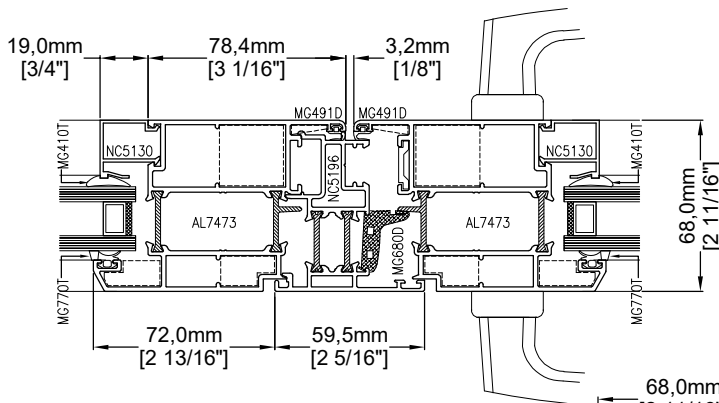
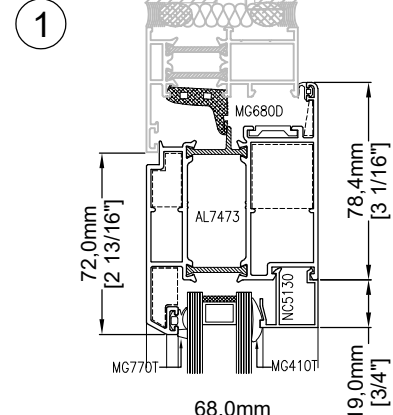
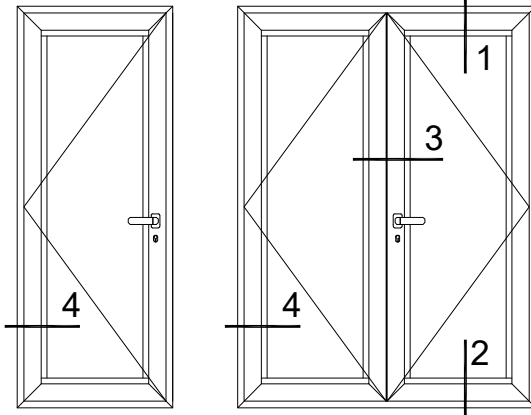

4

Porte
AL7675
Door

Volet / Sash	Divisions	Parcloles et épaisseurs de vitrage / Glass stops and thicknesses		
Porte Door	<p>NC5103 AL9955</p>	<p>NC5130 NC5130R AL1264 *</p> <p>25,0mm [1"]</p>	<p>NC5128 AL8215 *</p> <p>33,0mm [1 5/16"]</p>	<p>NC5127M *</p> <p>40,0mm [1 9/16"]</p>

* Parcloles / Glass stops performance: AW

Ouvrant extérieur / Outswing

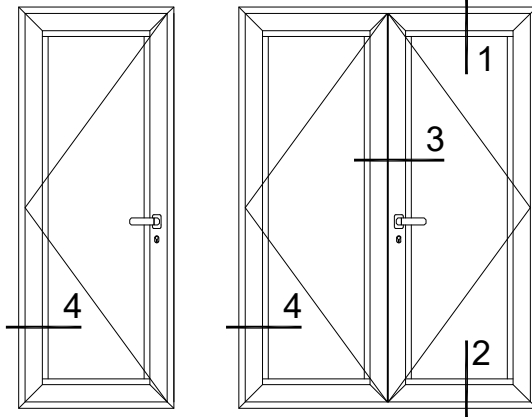

1

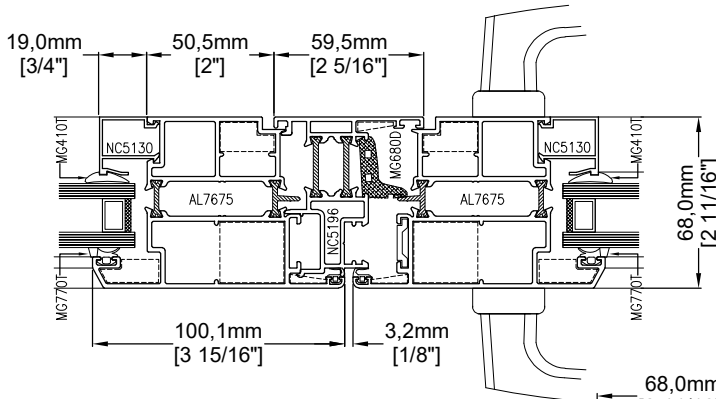
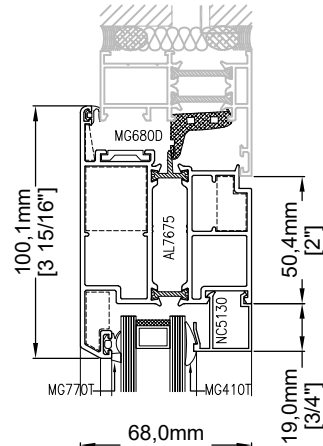

3

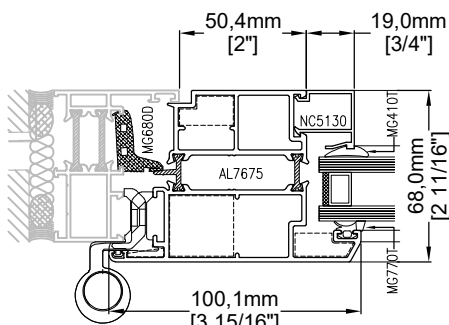

4

Porte
AL7675
Door

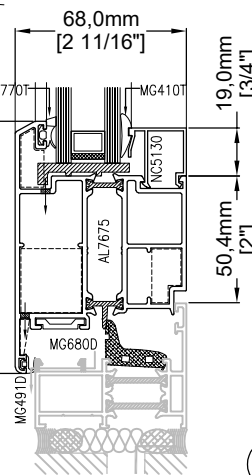

2

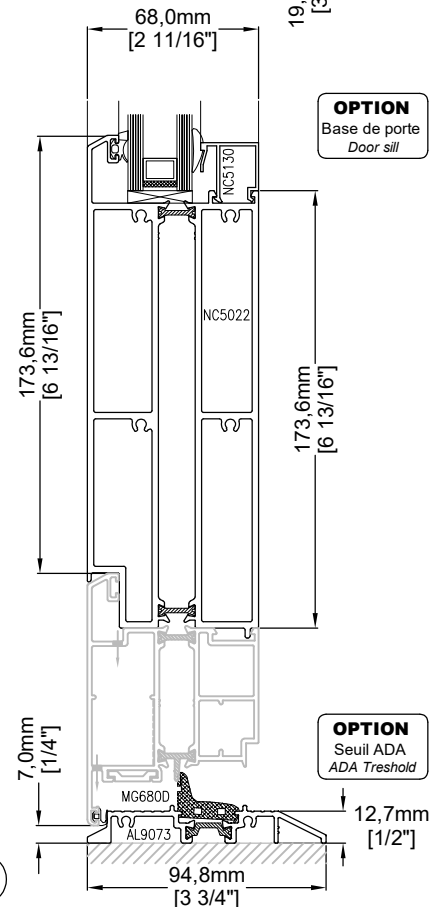

OPTION
Base de porte
Door sill

OPTION
Seuil ADA
ADA Threshold

Volet / Sash	Divisions	Parcloles et épaisseurs de vitrage / Glass stops and thicknesses		
Porte Door	<p>NC5103 AL9955</p>	<p>NC5130 NC5130R AL1264*</p> <p>25,0mm [1"]</p>	<p>NC5128 AL8215*</p> <p>33,0mm [1 5/16"]</p>	<p>NC5127M*</p> <p>40,0mm [1 9/16"]</p>

* Parcloles / Glass stops performance: AW

Mur rideau / Curtain wall

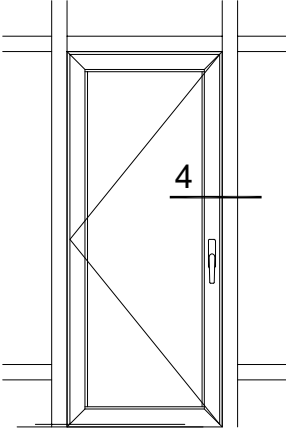

OUVRANT INTÉRIEUR INSWING

4

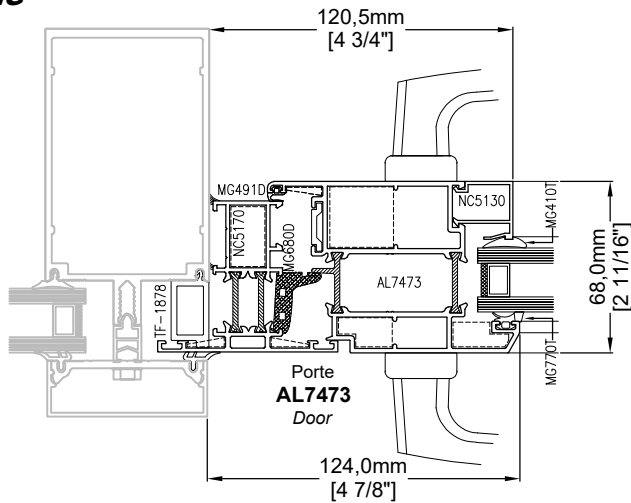



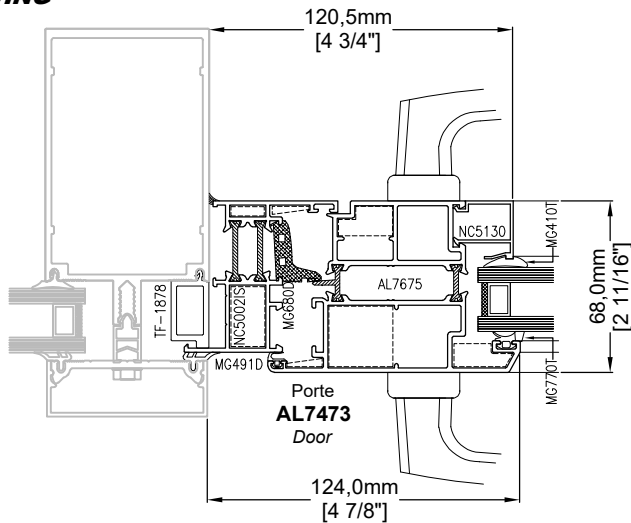

OUVRANT EXTÉRIEUR OUTSWING

4

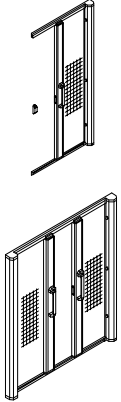

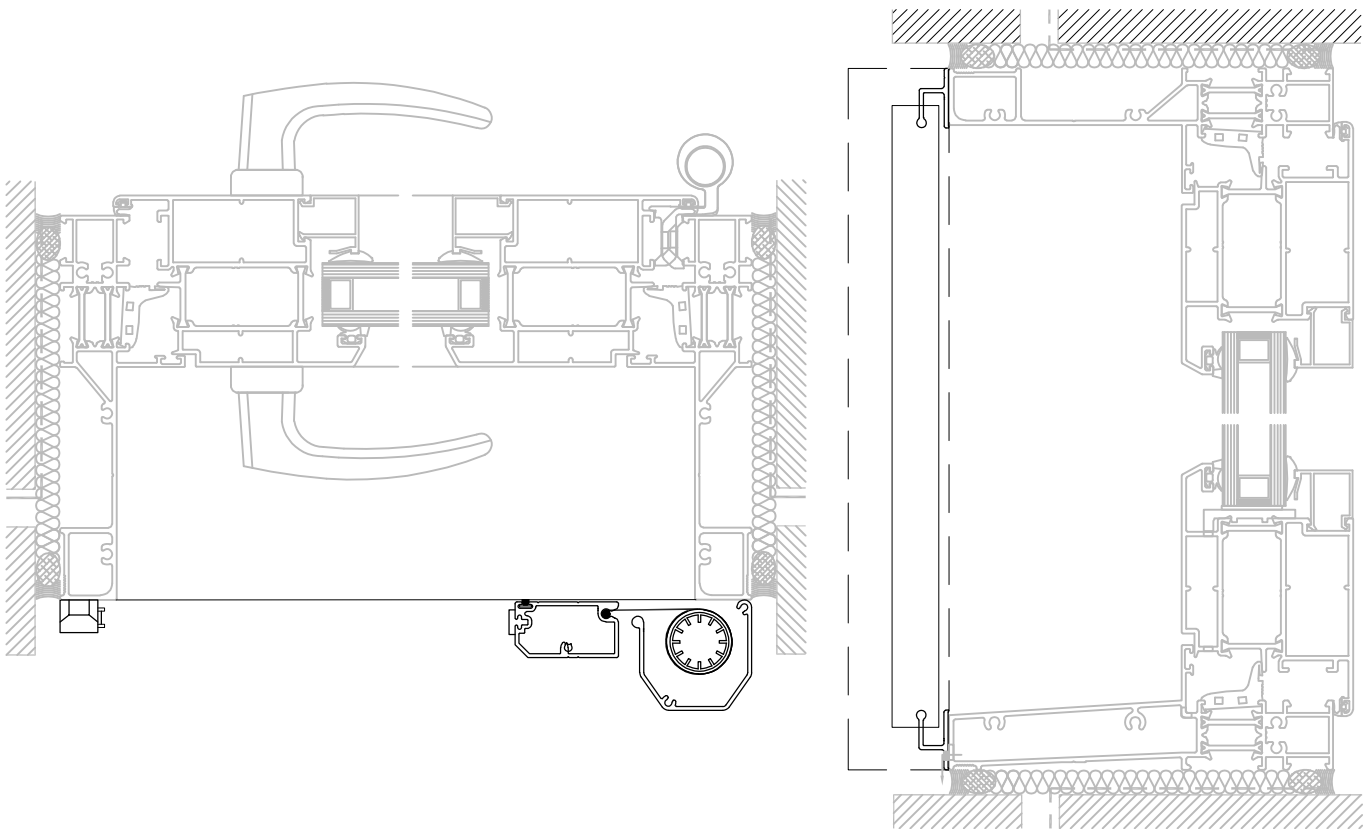

Moustiquaire / Screen

Image	Description	Quincaillerie <i>Hardware</i>	Pièces <i>Parts</i>
	<p>MS10</p> <p>Rétractable simple ou double <i>Single or double retractable</i></p>	<p>Poignée et aimant <i>Handle and magnet</i></p> <p>Mèche en aluminium noir 16 x 18 x 0,2mm en rouleau <i>Aluminum black mesh</i> 16 x 18 x 0,009" roll</p>	<p>Boîtier <i>Housing</i></p>  <p>Mèche coulissante <i>Sliding mesh</i></p>  <p>Rail</p>  

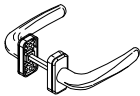
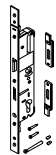
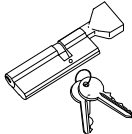
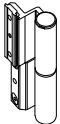
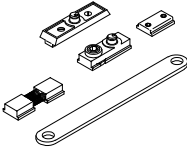
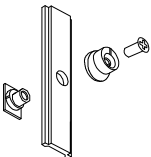
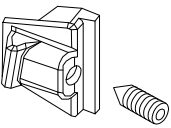
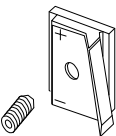
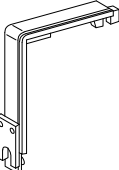

Quincaillerie Standard *Hardware*

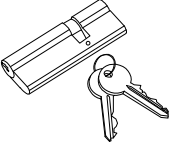
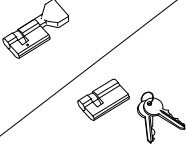
Image	Description	Numéro de pièce <i>Part number</i>	Note
	Poignée Prima pour porte terrasse <i>Prima handle for terrace door</i>	G02792	
	Serrure avec système multipoint <i>Lock for multipoint locking system</i>	G04646	
	Cylindre manuel intérieur et clé extérieure pour ouvrant intérieur <i>Cylinder with thumbturn - interior and key - exterior, for inswing</i>	G04636/G04637	
	Charnière ajustable robuste <i>Robust adjustable hinge</i>	F05657	
	Limiteur d'ouverture avec ressorts <i>Limit arm with springs</i>	G12953	
	Ensemble de fermeture ajustable multipoint pour volet <i>Adjustable multipoint closing system for sash</i>	G4030	
	Ensemble de fermeture ajustable multipoint pour cadre <i>Adjustable multipoint closing system for frame</i>	G1343	
	Gâche pour fermeture multipoint <i>Keeper for multipoint closing system</i>	G1350	
	Retour d'angle pour fermeture multipoint <i>Transmission angle for multipoint closing system</i>	G04019	

Options: Quincaillerie / Hardware			
Image	Description	Numéro de pièce <i>Part number</i>	Note
	Cylindre à clé intérieur et extérieur <i>Key cylinder - interior and exterior</i>	G07687	
	Demi cylindre <i>Half cylinder</i>	G04647 G04635	
	Ensemble de verrous affleurants pour paire de portes <i>Flush bolt for pair of doors</i>	G02008 G01339	