

FENÊTRE COLONIALE

La gamme de profilés d'aluminium de la Série 68 STH permet la production de différents cadres de fenêtre coloniale de type imitation guillotine ouvrant vers l'intérieur avec volets à trémie.

Ce système de fenêtres, fabriqué par Alumico Architectural inc., est en conformité avec les caractéristiques suivantes:

La fabrication du système de fenêtres est faite selon le principe de l'écran pluvial. Les profilés d'aluminium extérieurs et intérieurs du cadre et du volet sont reliés par le système SUPERTHERMIK 68™ composé de deux barrettes de polyamide de nylon 6/6 renforcé de fibre de verre, extrudées mécaniquement, munies sur toute leur longueur de deux cordons de colle et assemblées par moletage et sertissage de façon à obtenir un ensemble solidaire résistant à une pression minimale en cisaillement de 400 Kg sur une longueur de 100mm. Le moletage et sertissage des profilés est réalisé en continu assurant la solidarité et l'étanchéité entre les profilés. Les coins des volets sont coupés à onglets, réunis et renforcés par des équerres d'assemblage pressées mécaniquement pour obtenir des joints robustes. L'assemblage hors tout du cadre a une **profondeur de 68mm (2 11/16") ou de 152mm (6")**. Les volets Réguliers, Classiques et Colonial ont une **profondeur de 68mm (2 11/16")**. Les parclozes de type carrées ou arrondies s'installent à pression et sont munies d'une garniture pare-air/eau profilée à double densité. Toutes les composantes d'aluminium sont faites de l'alliage 6063 de la trempe T5.

COLONIAL WINDOW

The range of aluminum profiles from the 68 STH Series allows the production of various colonial window frames that resemble hung windows, with inswing hopper sash. This window system, manufactured by Alumico Architectural Inc., complies with the following specifications: manufacturing of the window system according to the rainscreen principle. External and internal aluminum frame and sash extrusions are connected using the SUPERTHERMIK 68™ system, which consists of two mechanically extruded glass-reinforced polyamide nylon 6/6 struts, each equipped along its entire length with two adhesive strips, knurled and crimped to achieve a solid assembly resistant to a minimum shearing pressure of 400 kg over a length of 100 mm. The knurling and crimping of profiles are continuous, ensuring the integrity and seal between them. The corners of the sash are miter-cut, joined, and reinforced by mechanically pressed assembly brackets to obtain robust joints. The frame assembly can accommodate **depths of 68 mm (2 11/16") and 152 mm (6")**. Regular, Classic or Colonial sashes have a **depth of 68 mm (2 11/16")**. The glass stops are of the square or rounded type, equipped with a pressure and air/water barrier gasket of dual density profile. All aluminum components are made of 6063 alloy with T5 temper.

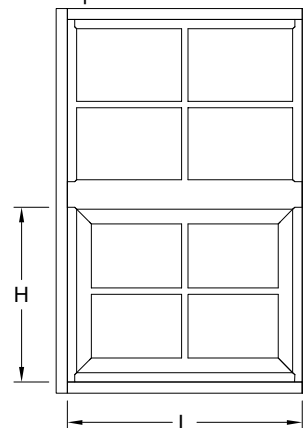

Dimensions limites de volet Limit Sash Dimensions

Régulier
AL0734
Regular

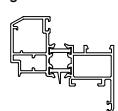

Classique
NC5201
Classic

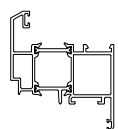

Colonial
AL5005

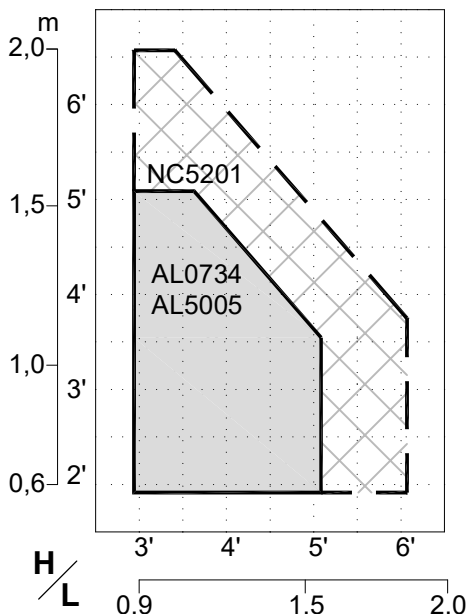
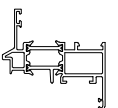

Poids maximum du volet
Maximum Sash Weight 80 kg

Quincaillerie Hardware	Numéro de pièce Part Number
STANDARD	
Crémone Prima <i>Prima cremone</i>	G01024
Bras de friction <i>Friction arm</i>	AMC-210/216/224
Limiteur d'ouverture <i>Limit arm</i>	G12952 & G12953
Ensemble de fermeture multipoint <i>Multipoint closure kit</i>	G1343 & G4030 &G1350
Fermeture multipoint avec retour d'angle <i>Multipoint closure system with back angle</i>	G04019
Moustiquaire amovible ou anti-vandalisme <i>Removable or vandal-proof screen</i>	MS01 & MS02
OPTIONS	
Crémone Prima à clé <i>Prima cremone with lock</i>	G01012
Crémone Prima pour perche et perche à crochet <i>Prima cremone for pole and hook pole</i>	G01024P PRH06 & PRH12
Crémone Euro et poignée amovible <i>Euro cremone for removable handle</i>	G01001 & G01130
Crémone et système de fermeture à ressort <i>Cremone and spring latch locking system</i>	G01024R
Opérateur à chaîne motorisé <i>MotORIZED chain operator</i>	VARIA-T
Limiteur d'ouverture <i>Limit arm</i>	AMC-211-6
Moustiquaire anti-vandalisme avec mèche en acier inoxydable <i>Vandal-proof screen with STS mesh</i>	MS03

Détails techniques disponibles
www.alumico.com
Technical details available

Volet régulier / Regular sash

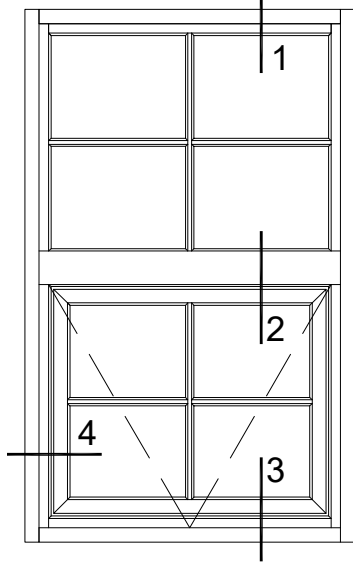

1

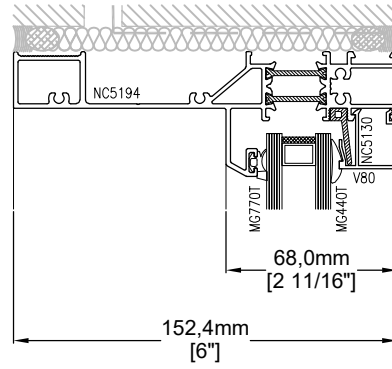

2

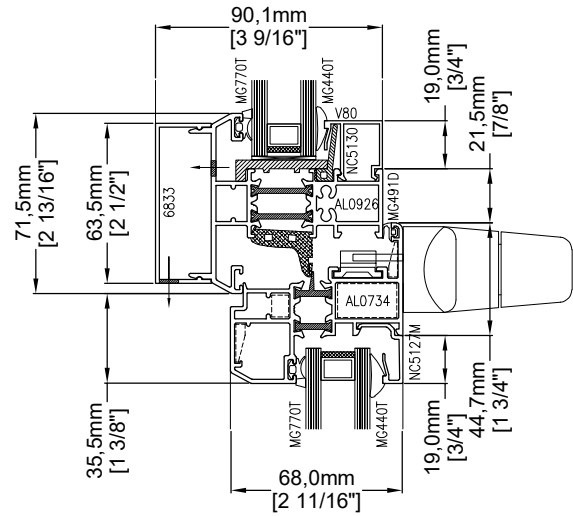

3

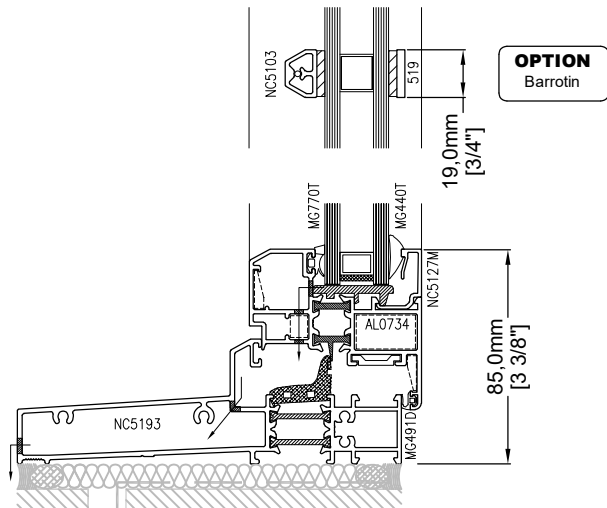

OPTION
Barrotin

4

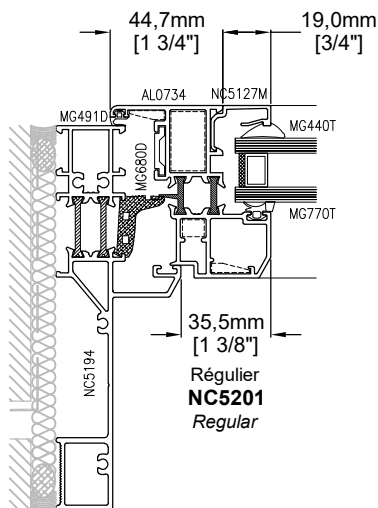

Volet colonial et classique / Colonial and classic sash

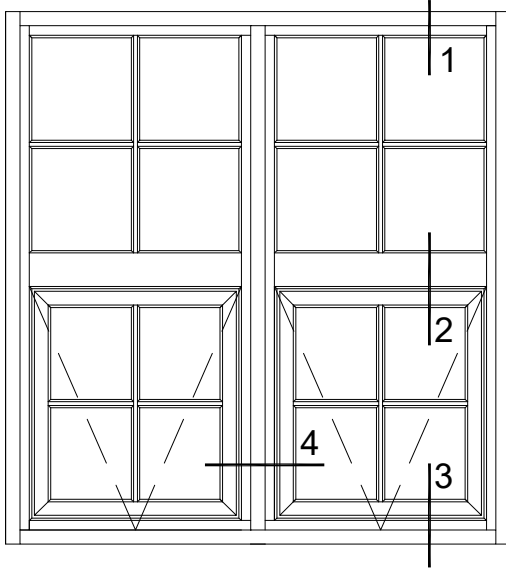

1

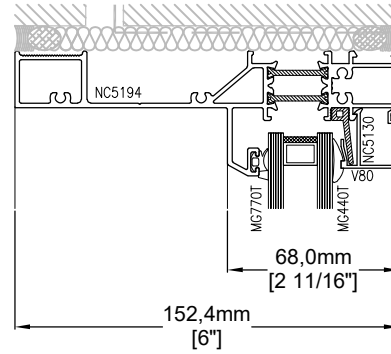

2

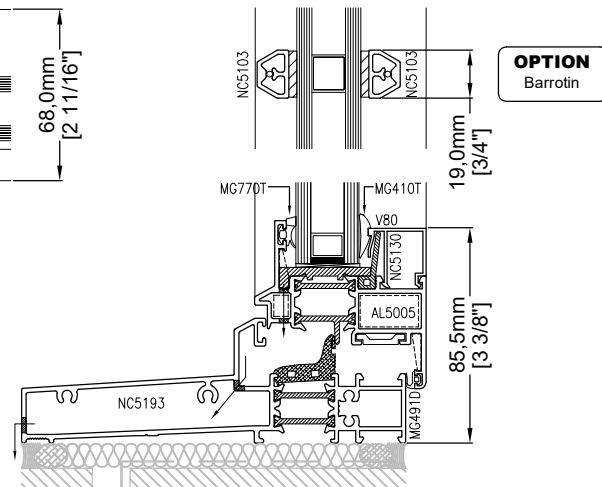
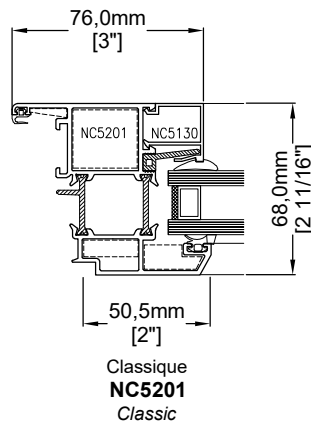
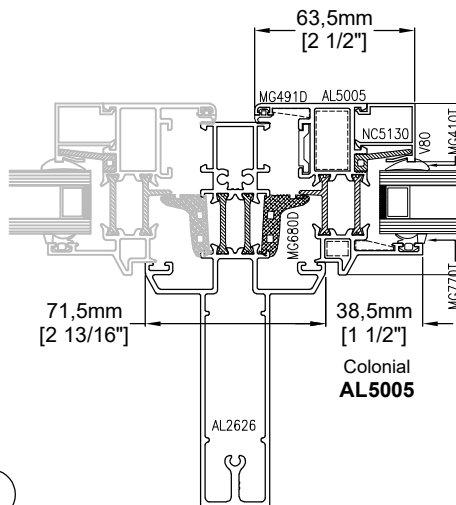
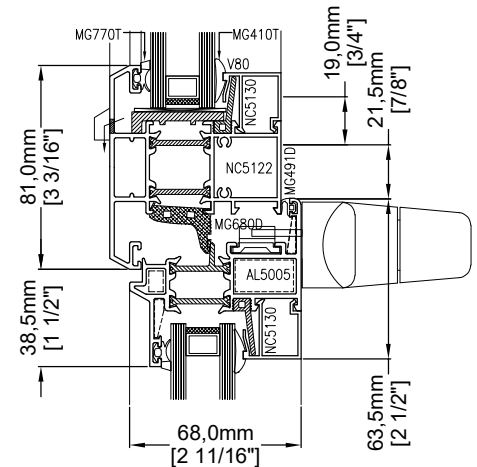

4





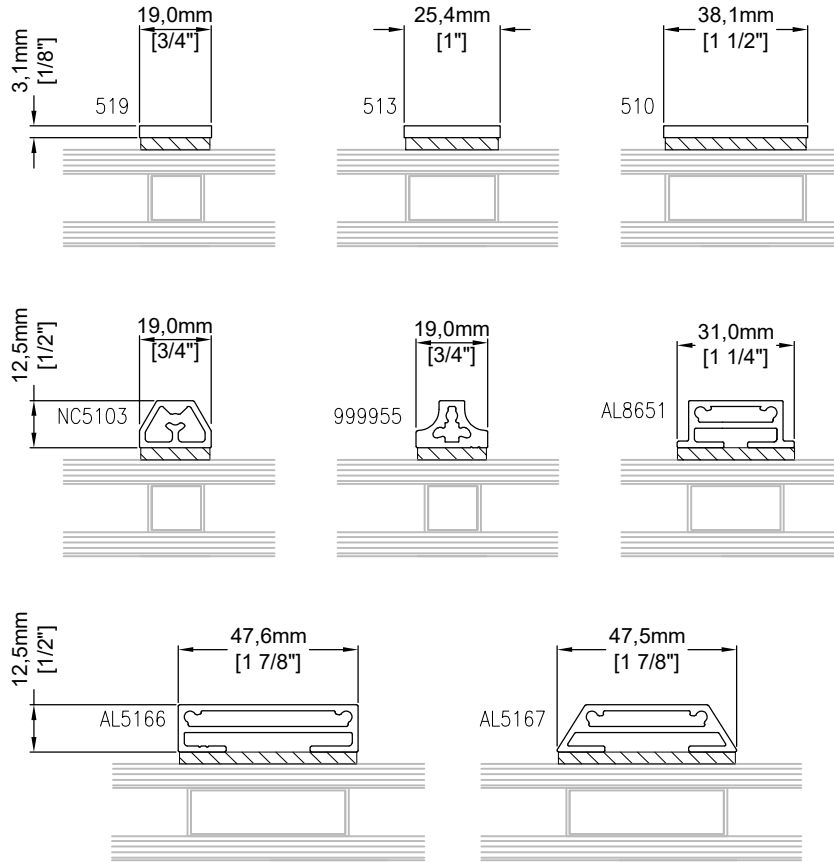

3

Barrotins

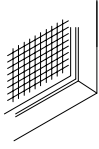
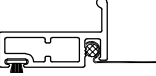

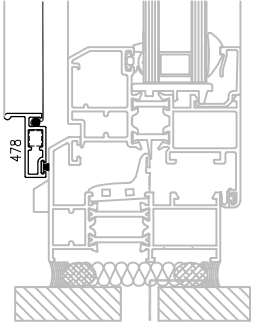
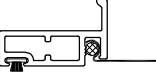

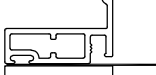
Volet / Sash	Divisions	Parcloses et épaisseurs de vitrage / Glass stops and thicknesses
Regulier Regular		NC5127M *
Classique Classic		NC5130 NC5130R AL1264 * NC5128 AL8215 * NC5127M *
Colonial		NC5130 NC5130R AL1264 * NC5128 AL8215 * NC5127M *

* Parcloses / Beads performance: AW

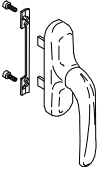
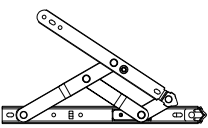
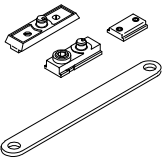
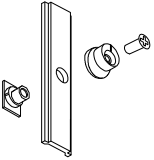
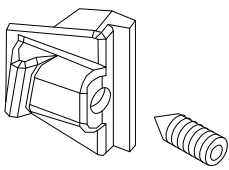
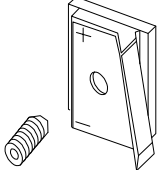
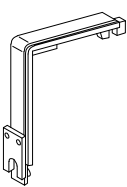
Moustiquaire / Screen			
Image	Description	Numéro de pièce <i>Part number</i>	Detail
	<p>MS01</p> <p>Mèche: Aluminium noir 16 x 18 x 0,2mm <i>Mesh: Black aluminum 16 x 18 x 0,009"</i></p> <p>Fixation: Attaches amovibles <i>Fastening: Removable clips</i></p>	<p>478</p>  <p>00201</p> 	
	<p>MS02</p> <p>Mèche: Aluminium noir 16 x 18 x 0,2mm <i>Mesh: Black aluminum 16 x 18 x 0,009"</i></p> <p>Fixation: Anti-vandalisme <i>Fastening: Vandal-proof</i></p>	<p>478</p>  <p>Torx® security</p> 	
	<p>MS03</p> <p>Mèche: Acier inoxydable noir/gris 12 x 12 x 0,5mm <i>Mesh: Black/Grey stainless steel 12 x 12 x 0,023"</i></p> <p>Fixation: Anti-vandalisme <i>Fastening: Vandal-proof</i></p>	<p>478 + 513</p>  <p>Torx® security</p> 	

Quincaillerie Standard <i>Hardware</i>			
Image	Description	Numéro de pièce <i>Part number</i>	Note
	Crémone Prima <i>Prima Cremona</i>	G01024	
	Bras de friction <i>Friction arm</i>	AMC-210 AMC-216 AMC-224	
	Limiteur d'ouverture <i>Limit arm</i>	G12953 G12952	
	Ensemble de fermeture ajustable multipoint pour volet <i>Ajustable multipoint closing system for sash</i>	G4030	
	Ensemble de fermeture ajustable multipoint pour cadre <i>Ajustable multipoint closing system for frame</i>	G1343	
	Gâche pour fermeture multipoint <i>Keeper for multipoint closing system</i>	G1350	
	Retour d'angle pour fermeture multipoint <i>Transmission angle for multipoint closing system</i>	G04019	

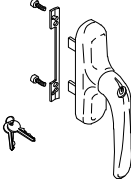
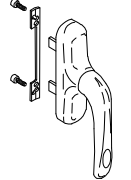
Options : Quicailerie / Hardware

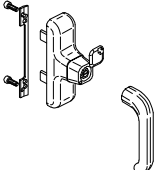
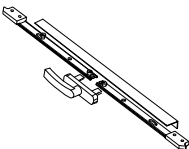
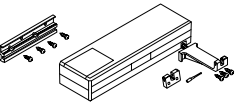
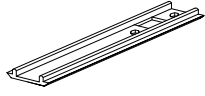
Image	Description	Numéro de pièce <i>Part number</i>	Note
	Crémone Prima à clé <i>Prima cremone with lock</i>	G01012	
	Crémone Prima pour perche <i>Prima cremone for hook pole</i>	G01024P	
	Perche à crochet <i>Hook pole</i>	PRH06 (1,8m/6') PRH12 (3,6m/12')	
	Crémone Euro pour poignée amovible <i>Euro cremone for removable handle</i>	G01001	
	Poignée amovible pour Crémone Euro G01001 <i>Removable handle for Euro Cremone G01001</i>	G01130	
	Crémone et système de fermeture à ressort <i>Cremone and spring latch locking system</i>	G01024R	
	Operateur à chaîne motorisé <i>Motorized chain operator</i>	VARIA-T	Finis Disponibles: <i>Available finishes:</i> - Blanc / <i>White</i>
	Limiteur d'ouverture pour bras de friction <i>Friction arm opening limiter</i>	AMC-211-6	